



Characteristics



- Self-supporting steel casing finished structural white colour RAL 9010.
- Cross-flow fans with conventional 2 speed motor.
- Electrical elements PTC type, resistances manufactured with a ceramic semi-conductor. Power contactors included.
- Control of the unit through remote control with infrared or with the control panel integrated on the equipment.
- Wall mounting support included.

Specifications

		ECO 1000 E	ECO 1200 E		ECO 1500 E	
Power (Fan)	W	140/200	150/230		200/300	
Voltage	V	230V~1	230V~1		230V~1	
Current	A	0,38/0,63	0,46/0,72		0,57/0,88	
Speed	rpm	1.350	1.350		1.350	
Airflow Min./Max.	m ³ /h	950/1025	1225/1300		1500/1625	
Power (Heating)	kW	6,2	7,4	7,4	9,3	9,3
Voltage (*)	V	400V~3	400V~3	230V~1	400V~3	230V~1
Current	A	8,7	10,4	18,5	13	23,3
Temperature Rise	°C	18/17	17/16	17/16	17/16	17/16
Weight	kg	16	18,2		22,9	
Noise Level	dB(A)	65	67		69	
Maximum Height (**)	m	2,2	2,2		2,2	

(*) "E" Standard models are with electrical heating at 400V three phase. "E230" Optional models at 230V single phase.

(**) Depending on installation conditions

Dimensions

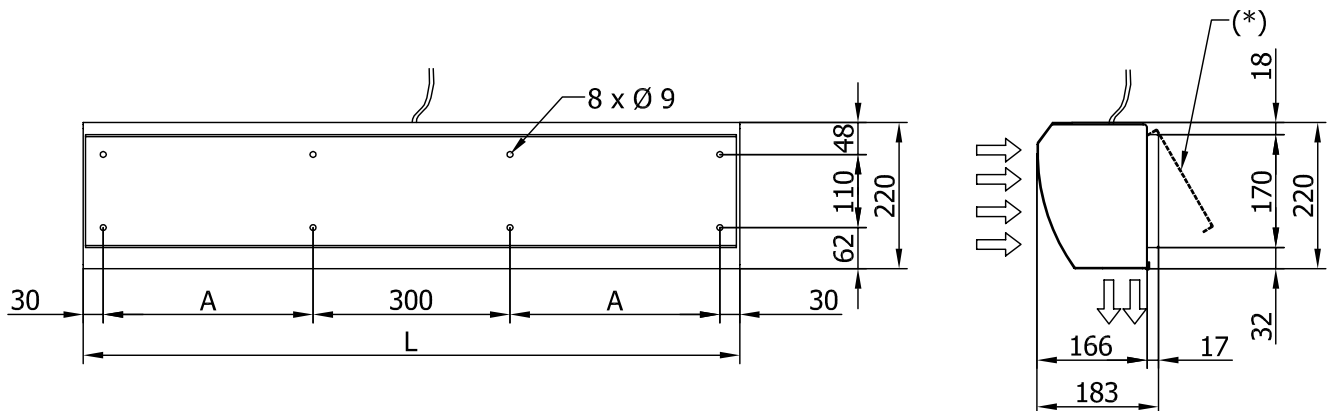

(*) Wall mounting support included

	L	A
ECO 1000	1000	320
ECO 1200	1200	420
ECO 1500	1500	570

